







Accessoires pour couplemètre

Accessoires	Code	Référence	Descriptif Capacité
	46 15 38680	HT-DC-4	Mandrin Ouverture : 0.5~4mm Poids : ~100g
	46 15 38685	HT-DC-6.5	Mandrin Ouverture : 0.5~6.5mm Poids : ~200g
	46 15 38690	HT-DC-13	Mandrin Ouverture : 1.2~13mm Poids : ~600g *Pour série HTG ≥ 5 Nm
	46 15 38720	HT-DBH	Tournevis dynamométrique Convient pour mesurer couple de vissage-dévisserie Embouts : ⊕: N°1×L50 ⊕: N°2×L50 ⊖: N°3×L50 Poids : ~100g

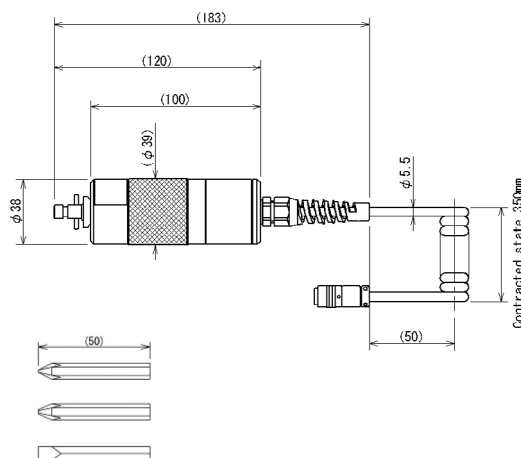

Accessoires	Code	Référence	Descriptif Capacité
	46 15 38730	HT-9.5SQ	Embout carré mâle pour le contrôle des clés dynamométriques ou autres usages Embout : carré mâle 9.5mm Poids : ~100g
	46 15 38750	HT-AD-M10	Adaptateur universel Filetage : M10 x L20 Poids : ~50g

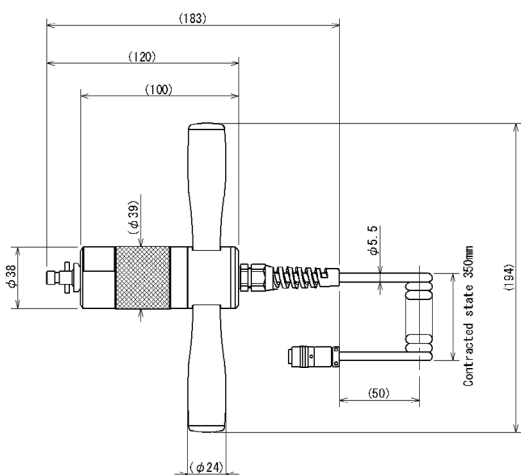

Support SHT-5N pour couplemètre série HTG

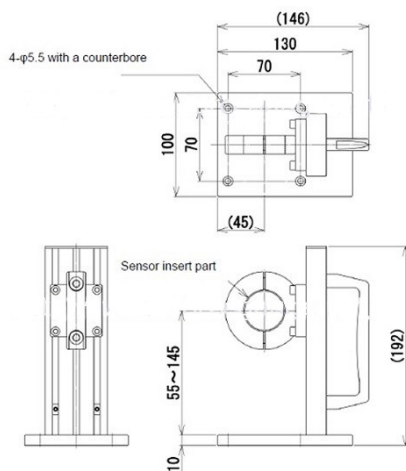
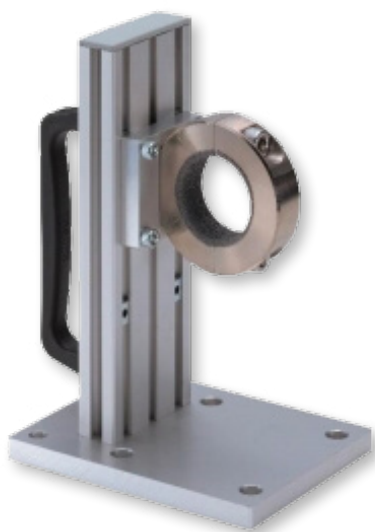

Caractéristiques :

- ✓ 5Nm (500Ncm)
- ✓ Poids : ~1100g
- ✓ Support basculant pour mesures verticales ou horizontales
- ✓ Peut être fixé sur le plan de travail

code	Référence	Gamme
46 15 38780	SHT-5N	2Nm & 5Nm

